

# Tilt Mount Frame Guide

18/06/2015

The Mounting Frame systems come pre-packaged to ensure the most streamlined and simple assembly process. Follow the steps below to assemble the tilt mount frame.

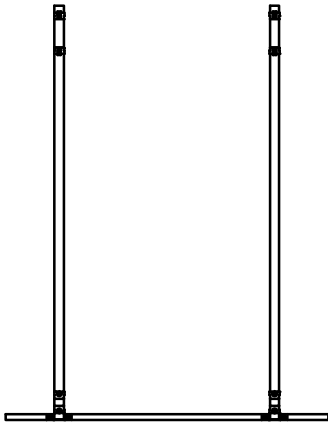

**Step 1:**  
Ensure that you do the following:  
Lay the first roof rail down horizontally as well as align the two front tracks in parallel to one another, and perpendicular to the bottom roof rail.

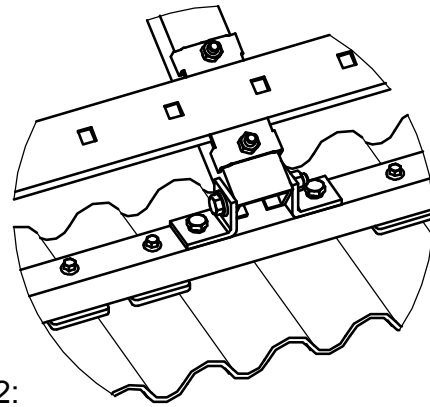

**Step 2:**  
Attach the front tracks perpendicular to the bottom roof rail using L brackets. Finger tighten all nuts and bolts. Ensure the track is placed in the right location based on the batten/purlin, spaced either 1500mm or 1800mm apart.

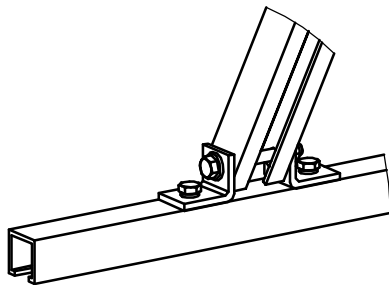

**Step 3:**  
Lay the top roof rail in parallel to the bottom roof rail, and attach the rear legs using L-brackets. Finger tighten all nuts and bolts.

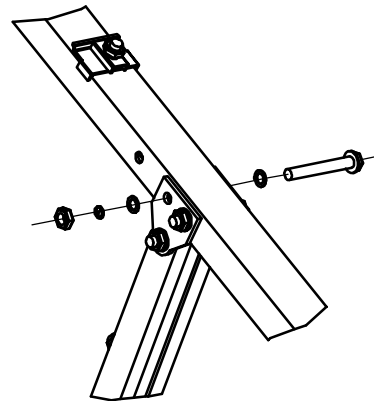

**Step 4:**  
Attach the front tracks to the rear legs using tri-attachment plates (top) and finger tighten all nuts and bolts.

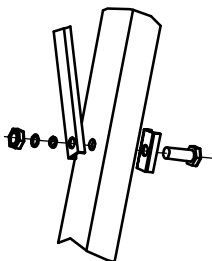

**Step 5:**  
Attach the X Brace to the rear legs and finger tighten all nuts and bolts.

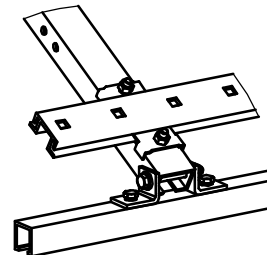

**Step 6:**  
Slide the bottom track into the bottom attachment plates. Using a spanner, tighten all nuts and bolts used for attachments for all steps 1-6.

# Tilt Mount Frame Guide

18/06/2015

Refer to the figure below for a labelled diagram of a Tilt Mount Frame.

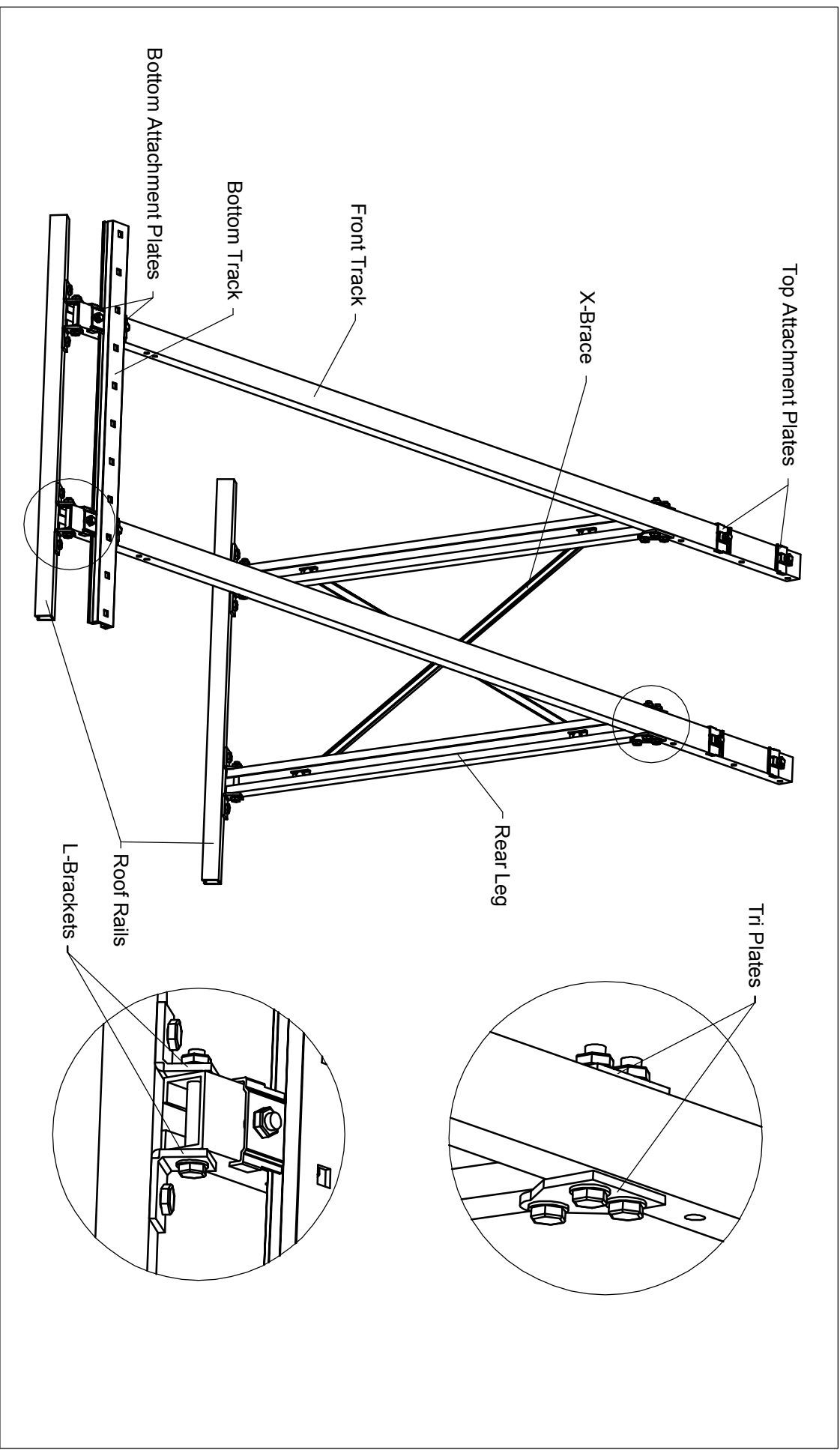

Labelled Diagram of Tilt Mount Frame

Apricus Australia